



DCR Power Controller for IONPURE® CEDI

DCR POWER CONTROLLERS FOR IONPURE® CEDI MODULES

SINGLE-PHASE DC POWER RECTIFIER FOR USE WITH CEDI MODULES

Digital Communication Rectifiers (DCR) from IONPURE® Products allow for constant control of power applied to Continuous Electrodeionization (CEDI) modules to optimize system performance. Standardized individual rectifiers improve performance, reduce cost and provide a simplified solution to supply power to CEDI modules. Designed to power the IONPURE MX, LX, and VNX CEDI modules.

Digital Communication Rectifier - IP-DCR600V15A-M

The DCR rectifier is a highly-reliable, compact single-phase DC power controller that features a high performance microprocessor, designed to efficiently control resistive loads. On-board digital communication allow for easy integration with existing PLC/HMI through the use of MODBUS® RTU or 4-20mA signals. A dedicated touch panel display is also available (IP-POWERDSP-TP).

Analog / Retrofit DCR - IP-DCR600V15A-R2

G2 power controller users can easily replace one or upgrade all G2 power controllers within their existing power cabinet with the Retrofit DCR rectifier for improved transient voltage protection and higher efficiency.

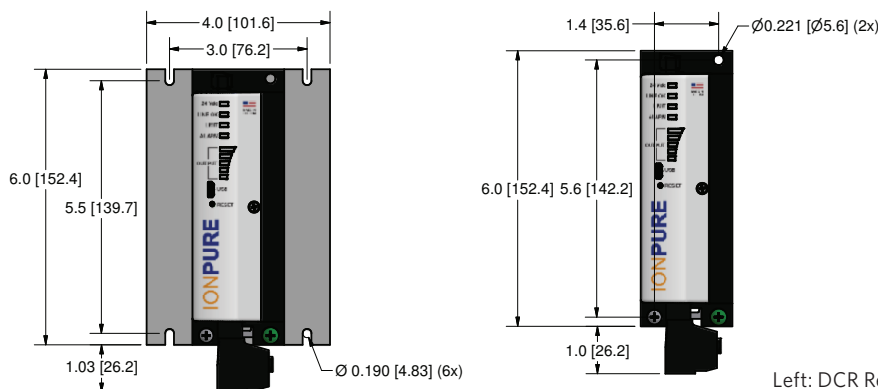

Left: DCR Retrofit Unit IP-DCR600V15A-R2
Right: DCR DIN rail Mountable IP-DCR600V15A-M

DCR Power Controller Features

- Compact DIN rail mountable design
- Universal Input
 - UL 24 - 600VAC
 - CE 24 - 660VAC
 - 45 - 65Hz
- Up to 600 VDC output (90% of AC Input)*
- MODBUS RTU or 4-20mA digital output
- Selectable constant voltage operation or constant current operation
- 5 Selectable Amperage output (0 - 2.5 A, 0 - 4.0 A, 0 - 6.5 A, 0 - 10.0 A, and 0 - 15 A)
- 24 VDC input to control electronics and maintain critical communications
- Compact touch safe fully-enclosed design
- Soft start protection - Dedicated run/stop bit
- Microprocessor controlled
- On-board diagnostics
- Designed and Manufactured in the USA
- Retrofit version available for G2 users
- Available IONPURE power software for configuration and troubleshooting

For additional information on this DC rectifier and other IONPURE products visit our website at www.ionpure.com

* DCR-M only

Specifications

AC INPUT	
Line Voltage (auto ranging) ¹	UL: 24 - 600 VAC CE: 24 - 660 VAC
Phase	Single
Frequency (auto ranging)	45 - 65 Hz
DC INPUT	
Voltage	24V
Current/Amperage	0.3 A
DC OUTPUT	
Voltage	20 - 600 VDC
Current/Amperage	0 - 15
Selectable Amperage Ranges	0 - 2.5 A 0 - 4.0 A 0 - 6.5 A 0 - 10.0 A 0 - 15.0 A

Communications

Programming port	USB
Fieldbus Protocol	MODBUS RTU (RS-485) ²
Connections	RJ-45 (2x)
Terminating resistor	dip switch enable
Positioning	16-Position rotary dial
Parameters	All settable parameters and monitor parameters such as set-point, current, voltage, warnings, faults, etc.
Connection To External Devices	PLC/HMI or IONPURE Touch Panel Display via fieldbus 0-5VDC for the retrofit version

¹ Requires isolation transformer to allow proper grounding of ED/CEDI module cathode

² Not available on retrofit version (-R2)

Operating Environment

Cooling	Heatsink and Natural Convection
Surrounding Air Temperature	0 - 50°C (32 - 122°F)
Altitude	< 6000 ft
Relative Humidity	< 95% (non-condensing)
Storage Temperature	-15 - 70°C (5 - 158°F)

Protections

Line Transients	Dual DVDT Network
Over-voltage	MOV + Voltage Limiting
Under-Voltage	Output alarm
Over Temperature	Manual Restart
Ground	Heatsink screw
Printed circuit Board	Conformal Coated
Touch Safe	Fully enclosed

Ordering Information and Physical Specifications

Order #	Model #	Description	Width	Height	Depth
W2T827123	IP-DCR600V15A-M	DC RECTIFIER, 600VDC 15A DIN Rail mountable with MODBUS communication	1.4 in (35.6 mm)	6.0 in (152.4 mm)	5.2 in (132.4 mm)
W2T827122	IP-DCR600V15A-R2	Retrofit DCR Rectifier, 600VDC 15A w/ 0-5 VDC communication / Replacement for G2 and PCB power controllers	4.0 in (101.6 mm)	6.0 in (152.4 mm)	5.34 in (135.6 mm)
W2T829935	IP-POWERDSP-TP	4.3" Touch Panel Display (for DCR-M and DC3 only)	5.04 in (128 mm)	4.02 in (102 mm)	1.26 in (32 mm)



AQUAANALYTIC LLC



Business Center 1, M Floor,
The Meydan Hotel, Nad AlSheba,
Dubai, U.A.E.

+31 715 69 01 51

<https://aquaanalytic.ae>
info@aquaanalytic.ae