

## PACIFIC OZONE™ PC SERIES PORTABLE CART



### PORTABLE DISINFECTION FOR SPEED AND FLEXIBILITY

Portable ozonated water production has never been easier or more flexible. The PC Series of portable ozone water contacting systems bring together Evoqua's Pacific Ozone™ system's revolutionary air-cooled corona discharge ozone technology in compact and completely integrated ozone contacting systems. These durable, mobile units provide ozone production comparable to that of permanently installed ozone contacting skids. The PC delivers 36 grams per hour, nearly 2 pounds per day.

With the Pacific Ozone™ Packaged generator systems, all you need is air, water, and electricity to increase the efficiency and safety of your process.

### COMPLETE, POWERFUL AND MOBILE

Originally developed for the wine industry, the PC Series performs tank sanitization, barrel washing, surface disinfection, and clean-in-place (CIP) of tanks and piping. Portable ozone disinfection with the PC Series is ideal for sanitizing surfaces in food and beverage applications including dairy, brewing, fresh-cut produce, seafood, processed foods, and meat and poultry. The mobility of the PC Series provides dissolved ozone wherever it is needed – at various sites within a single facility, or even at multiple locations for diverse on-site applications.

### EASY TO INSTALL AND OPERATE

The PC series portable ozone systems are factory tested and ready to use, units require only a single point power connection and feed gas to produce high concentration ozone from the air-cooled enclosure. No cooling water is required, simplifying the process. Power is supplied by standard 120V or 240V 50/60Hz line voltage, depending on the configuration. Standard PC Series control features offer everything a process scheme requires for automatic operation and integration with other process system protections and safety configurations. The seamless operation and integration will provide you assurance in your process.

### PEACE OF MIND IN PERFORMANCE

The PC Series offers proven and reliable ozone output. The performance can easily be verified, when required, delivering qualified and verifiable performance. With the real-time monitoring and the quality design, the units require less maintenance and provide more process uptime to keep your production efficiency high. All PC Series systems are engineered to meet all of the ozone process requirements found in the most demanding applications; yet, they are easy simple to operate and easy to move or store, and will provide years of trouble-free operation, providing a solution for today and tomorrow.

### FEATURES

- All Stainless-Steel Construction
- Air-Cooled FPT Titanium Reactor Cells
- No Cooling Water is Required
- Precision Linear Ozone Control by Powertron
- On-Board Concentrated Oxygen
- Side-Stream Ozone Injection
- Variable output up to 36g/h
- Ozone Output Control
- Degas Column with Destruct Catalyst
- Over-Temperature Protection

### BENEFITS

- Dissolved Ozone Water On-demand
- Easy and Quick to Use, Set-Up and Store
- Rugged and Compact Design
- Designed for Safety
- Visual Ozone Output Indicator
- Simple Use and Control
- Automatic Water Flow Switch
- Ideal for Supplementing Existing Sanitizing Processes

### MARKETS

- Aquaculture
- Food & Beverage

## THE POWERTRON DIFFERENCE

Powertron is our latest innovative technology aimed at helping you maximize your operational efficiency. Now integrated into our complete product lineup, this novel power supply design provides a new method to control power for precision O<sub>3</sub> output that uses less energy. With 100% linear turndown capability, this advanced technology provides a stabler and quieter performance with its enhanced, robust design. The patented design offers revolutionary and precise control of the power in the cell to produce the corona, so energy does not become wasted heat. The design allows for unique monitoring of electrical parameters to deliver energy reliably and efficiently, improving performance and reducing maintenance needs.

## ACCESSORIES

The following accessories are recommended for use with the PC Series:

- Pressure Regulating Valve, W3T514399
- Spray Nozzle & 25 ft. Hose, W3T496910
- Spray Nozzle & 10 ft. Hose, W3T496909
- Ozone SAM Photometer Kit 0 - 075 ppm, W2T883159
- Ozone SAM Kit 0 - 5.00 ppm, W2T883160

## SIMPLE. PROVEN. OZONE TECHNOLOGY.

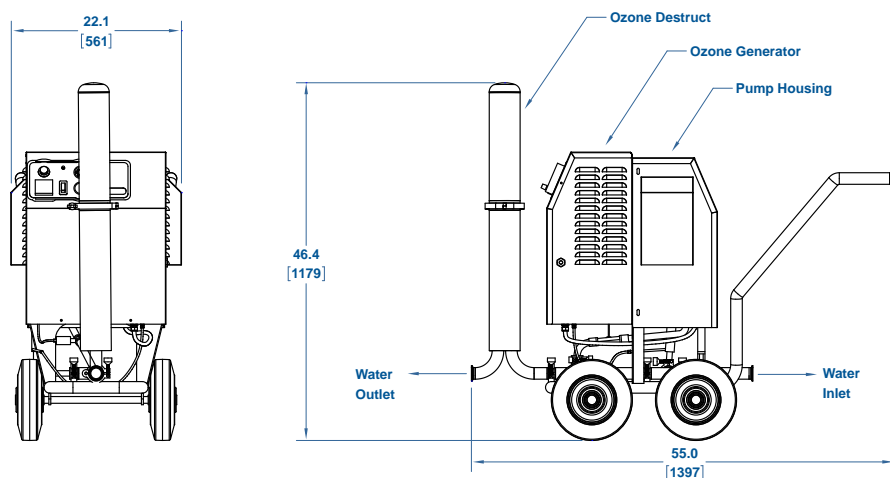

Ozone SAM Test Kit



Hose and Spray Nozzle  
(Accessories available at [evoqua.com](http://evoqua.com))

## TECHNICAL SPECIFICATIONS\*

Ozone Production (g/h)	Normal Flow (SCFH)	Reactor Cell Operating Pressure (psi)	Power Requirements	Amperage (A)	Dimensions WxDxH
36	20	6-9	1Ø, 120V, 50/60Hz	20	22.2 x 55 x 46.4
36	20	6-9	1Ø, 240V, 50/60Hz	10	22.2 x 55 x 46.4

\*Nominal, under standard conditions.



AQUAANALYTIC LLC



Business Center 1, M Floor,  
The Meydan Hotel, Nad AlSheba,  
Dubai, U.A.E.

+31 715 69 01 51

<https://aquaanalytic.ae>  
[info@aquaanalytic.ae](mailto:info@aquaanalytic.ae)